



MPPT

Solar Charge Controller



**MP
PT**

**SOLAR
CHARGE
CONTROLLER ▶**



Please read this manual carefully before use. This manual is subject to change without notice, and the company's interpretation of it shall prevail!

Preparation



1 Wiring

1. 1Preparation

1. Select the appropriate cable (fix the controller on the wall or other vertical planes (reserve 15cm or more space above and below the solar controller.)
2. prepare pliers and hydraulic clamps (for pressing copper cable joints), copper cable joints, wrench, multimeter , etc.

1. 2 Installation process



Note: Please turn off breaker of solar controller and solar panel before installing the controller. Do not touch the positive or negative terminals of the solar panel or battery during installation ,

Otherwise there is a risk of electric shock.

- (1). Install the controller on the wall and tighten the screws
- (2). Check the voltage of the battery and the solar panel array if they are within the required range.
- (3). Turn off overcurrent circuit breaker of battery or fuse and the solar panel array and load.
- (4). Connect the battery with the cable to the battery terminal on the controller and tighten the screws
- (5). Connect the load with cable to the load terminals on the controller and tighten the screws.
- (6). Connect the solar panel with cable to the PV terminals on the controller and tighten the screws.
- (7). Turn on the circuit breaker or fuse of the battery and check the system status on the LCD . (See Chapter 5 for more information about LCD.)
- (8). Turn on the switch or fuse of the solar panel and the controller starts to charge the battery.

Safety instructions



- (1) Please keep the installation site free from flammable, explosive or corrosive dust.
- (2) Please keep the controller out of direct sunlight or rain.
- (3) Please prevent foreign bodies or liquid near the controller
- (4) Please contact technician to dismantle or repair the controller.
- (5) Do not put metal objects next to the battery.
- (6) Do not touch the controller terminals or the back panel to prevent electric shock or burns.

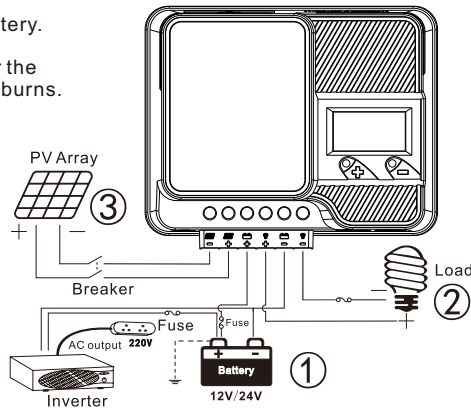

1.PRODUCT INTRODUCTION



Thank you for selecting MPPT series solar charge controller with the most advanced MPPT control algorithm and the maximum power point of the pv array can be quickly tracked in any environment so that it can get the maximum energy from the solar panel and significantly improve the utilization of energy in solar system. The machine has the dual display function of LCD and Remote meter (optional) and standard communication interface, convenient for user extension application and satisfy different monitoring needs to the maximum extent. It can be used in communication base station, home power supply system, traffic light, solar street lamp, courtyard lamp system, etc.

The features are listed below:

- Advanced MPPT maximum power point tracking technology, the tracking efficiency is no less than 99.5%.
- High quality components are used to improve the system performance, and the maximum conversion efficiency can reach 97%.
- Super fast maximum power tracking speed while ensuring tracking efficiency.
- Accurate identification and tracking of the maximum power point of multi-wave peak.
- Reliable maximum input power of pv array to ensure the safety of equipment.
- Wide pv array maximum power point operating voltage range.
- 12/24V automatic voltage identification.
- The LCD is designed to dynamically display the operation data and working status of the equipment.
- Various load control modes: general mode, light control mode, dual time mode, pure charger mode .
- Seal, GEL, Flooded, LifePO4 and Li(NiCoMn)O2 charging process can be selected.
- The function of battery temperature compensation.
- Power statistics recording function.
- Use the RS485methods to maximize the communication needs of different occasions.
- Support PC monitor, external display unit and other peripherals, realize real-time data view and parameter setting function.

2. Product appearance and interface

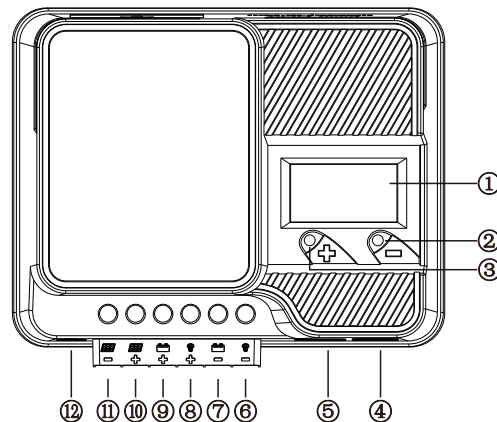

①	LCD
②	- Button
③	+ Button
④	USB output
⑤	RJ45 communication interface(optional)
⑥	Load Terminals -
⑦	Battery Terminals -
⑧	Load Terminals +
⑨	Battery Terminals +
⑩	PV Terminals +
⑪	PV Terminals -
⑫	External temperature sensor(optional)

Photo 1 Appearance



Noted: Without connecting the remote temperature sensor, the controller defaults to the ambient temperature as the battery temperature to compensate for the charging parameters

3. Product size and installation aperture

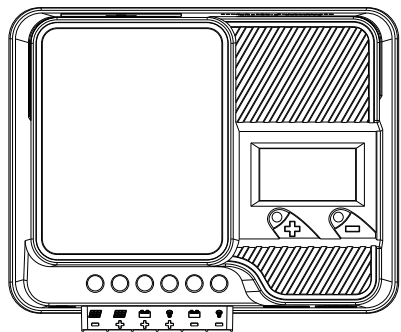

Current: 20A(12V/24V)&10A(12V/24V/36V/48V)
Size: 165x137x73mm
Installation aperture: 143x80mm
Diameter of aperture: ≥ 4.5 mm

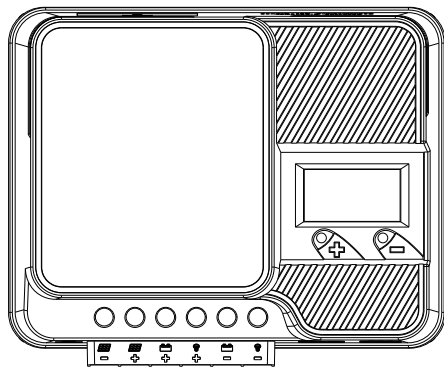

Current: 30A(12V/24V)&20A(12V/24V/36V/48V)
Size: 185x152x78mm
Installation aperture: 163x90mm
Diameter of aperture: ≥ 4.5 mm

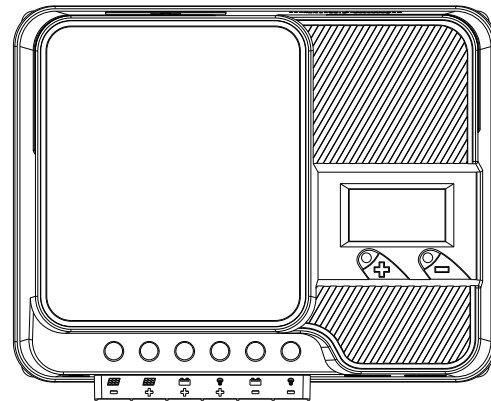

Current: 40A(12V/24V)&30A(12V/24V/36V/48V)
Size: 205x167x83mm
Installation aperture: 183x105mm
Diameter of aperture: ≥ 4.5 mm

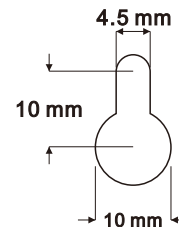

It is wall chart size,
with a separate installation paper

3. Wiring

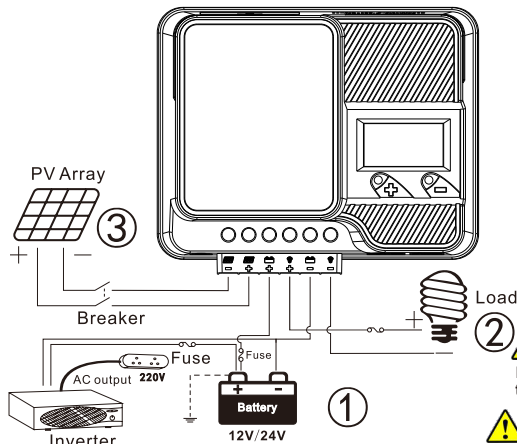

Figure 2 Connection diagram

Order of connection:

- ① Connect battery
 - ② Connected Load
 - ③ Connect pv array
 - ④ Controller is powered on
- Connect the battery, identify the voltage of the control system and observe whether the display screen is lighted. If it doesn't work or the display is abnormal, refer to section 6 for troubleshooting.

NOTICE: This series of MPPT is a common positive controller, pv array, battery and load of the positive pole can be grounded at the same time.

Note: If the inverter is connected to the system or other loads with large starting surge current, please Connect the inverter directly to the battery and never to the load side of the controller.

4. Operation

4.1 Button Function

Mode	Remark
Load switch	Press the "-" button lightly to switch the load.
Error Clearing	Press "-" button lightly .
Browsing mode	Press "+"/ "-" button lightly .
Setting mode	long press "+" button to enter the secondary browsing interface and then short press "+" or "-" to browse secondary interface, long press "+" button again to enter the setting mode, short press "+" button or "-" button to set parameters, then long press "+" button to save the settings. Long press "-" button or 15 seconds without keystroke operation will exit secondary browsing interface (parameters are not saved)

4.2 Button Function

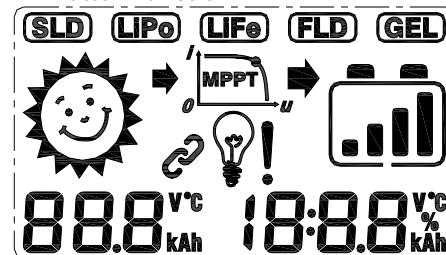

> Status Description

Item	ICO	Status
PV array		Day
		Night
Battery		Uncharged
		Charging
		Battery soc
		Battery type
LOAD		load on
		load off

4.3 BOOT SCREEN

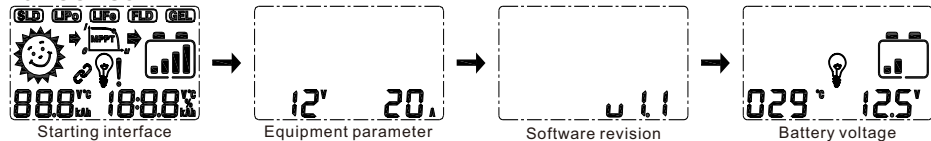

- (1) **Starting interface:** it is normal to detect LCD when the system is powered on.
- (2) **Equipment parameter:** Controller current system voltage and rated current.
- (3) Software revision.
- (4) **Battery voltage interface:** Battery voltage and ambient temperature .

Notice: At the first level browse interface long press **+** button to enter the secondary browsing interface .It will automatically exit the secondary browsing interface without doing anything for 15 seconds.

> First-level browsing interface

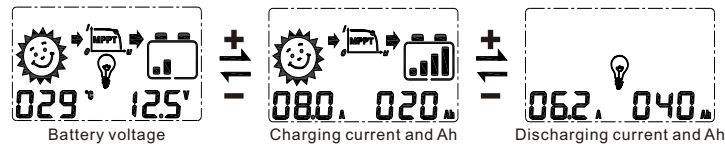

In the main loop interface, press the **+** or **-** button to switch pages , and long press the button **+** to enter the secondary browsing interface.

>Secondary browsing interface under the condition of battery voltage interface.

The secondary browsing interface consists of the following screens:

- Battery voltage interface:** 029' 125'
- Lithium battery constant voltage charging point:** 144'
- Voltage of Equalization charge:** E9U 146'
- Voltage of Absorption charge:** A65 144'
- Temperature compensation ratio:** tCr -04
- Load Mode:** Mod LN3
- Remote communication number:** no 001
- Floating charge voltage point:** FLt 138'
- System voltage:** SYS AUt
- Battery Type:** tYP USr
- Undervoltage recovery point:** Lur 126'
- Undervoltage protection point:** Lud 108'

Long press the **+** button in the main loop of the battery voltage interface to enter the secondary browsing interface, short press the **+** or **-** button to switch pages, long press the **+** button to enter the setting interface, short press **+** or **-** button to set the parameters and long press **+** to save .It will automatically exit the secondary browsing interface without doing anything for 15 seconds.

Battery voltage interface: 029' 125'

PV module voltage interface: 030' 138%

In the main loop of the battery voltage interface long press **-** button, switch to display solar array voltage (The % symbol serves as a distinction) and internal temperature of the controller (The letter h serves as a distinction)

The load pattern is as below (e.g for 12V system):

CODE	LOAD PATTERN
LN1 (LM1)	Regular Mode
LN2 (LM2)	Light control mode
LN3 (LM3)	Dual time mode
LN4 (LM4)	Charge only mode

- 1.Regular mode: The controller charges the battery, by pressing "-"button to switch load on/off.
- 2.Light control mode: when the controller detects that the voltage of the solar panel is higher than 5V, it is identified daytime and the load output will be automatically turned off; the controller detects that the voltage of the solar panel is lower than 6V, it is identified night and the load output will be automatically turned on.
- 3.Dual time period mode: light control with switch-off point at night and switch-on point before dawn. e.g, for 12V system, load is turned on for "n" hours after sunset(voltage <5V); and the load is turned on for "n" hours before sunrise.

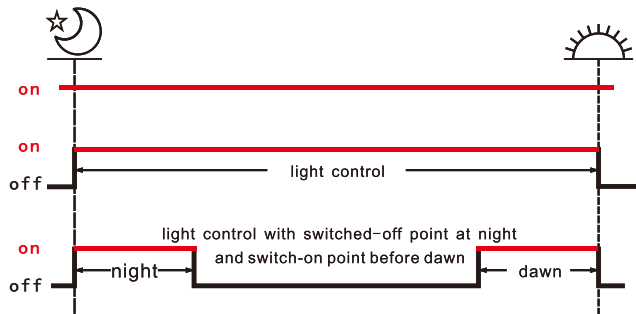

Load working mode

- 4.Charging mode: When the controller is turned on, load output is off by default.

➤ Dual time mode

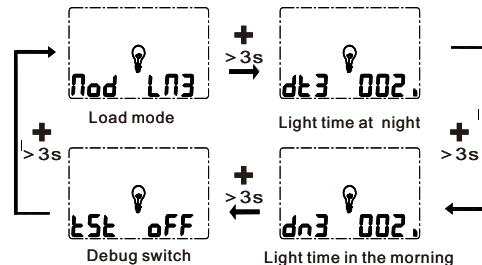

In load mode 3 (LM3), long press the + to enter the setting interface ,then short press + or - to set the parameters and save after long pressing + button.

➤ Fault indicator

Status	Chart display	Specification
Voltage shortage of storage battery		Flicker
Over voltage of storage battery		Flicker
Overloading trouble		Flicker

4.4 Battery type

Six types of battery for user choosing: User default, Sealed, Flooded, GEL, LiFePO4, Li(NiCoMn) O2. Among them, User default, LiFePO4, Li(NiCoMn) O2 can change parameters.

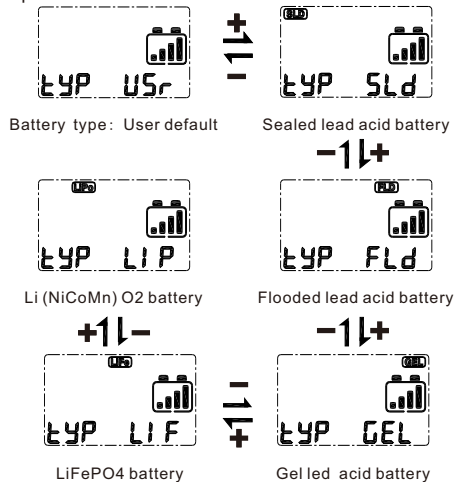

4.5 System voltage selection.

Long press **+** in the system voltage interface, enter the setting interface, short press **+** or **-** to select system voltage, long press **+** again to save the selected system voltage.

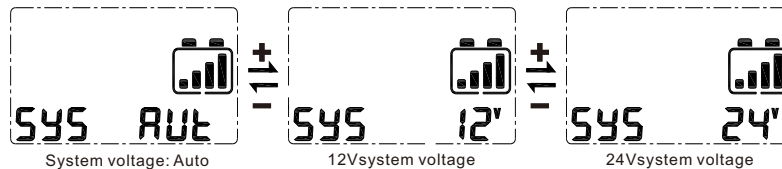

4.6 Restore factory Settings

Long press **+** for 3s to enter the factory setting in main loop discharging current interface

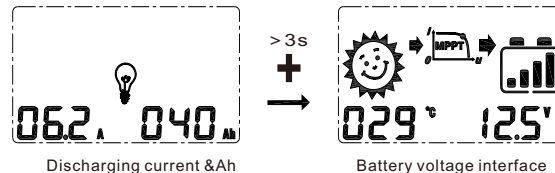

5. Protection function



Protection	Condition	Status
Solar panels is reversed	Solar panel can be reversed if battery is not connected	Controller isn't broken
Battery is reversed	Battery can be reserved if PV is unconnected	
Battery over-voltage	Battery voltage reaches the over-voltage point	Stop charging and discharging
Battery over-discharge	Battery voltage drops the under-voltage point	Stop discharging
Over-load	The load current is over the rated current	Output is closed Clear error Short press - button or restart controller

Note: You can short press "+" key to eliminate the error code.

6. Fault Management



Error code	Cause	Correction
No sign on the LCD when there is enough sunlight	PV array is connected wrongly	Check if connection of solar input is right and tight.
No sign on the LCD when connection is right	1. Battery voltage is less than 8v 2. Voltage of solar panel is less than battery voltage	1. Check battery voltage. Controller will start only battery voltage is more than 8v 2. Voltage of solar panel must be higher than battery voltage.
E 1 (Ex1)	Battery low-voltage	Load will be connected automatically when battery voltage recovers to the point of low-voltage protection.
E 2 (Ex2)	Battery over-voltage	Check if battery voltage is more than point of over-voltage protection and disconnect PV array
E 3 (Ex3)	Over-load	Please reduce the loads and check connection carefully
E 5 (Ex5)	High temperature	let controller cool. Recharge after cooling
E 6 (Ex6)	Over-temperature protection of solar panel input	Check configuration of solar panel to insure VOC of solar panel exceeds limit under the local lowest temperature
E 7 (Ex7)	Error code after changing controller system voltage.	Power off controller and restart

7. Technical Data

Rated charge current	20A (12V/24V)	10A (12V/24V/36V/48V)	30A (12V/24V)	20A (12V/24V/36V/48V)	40A (12V/24V)	30A (12V/24V/36V/48V)
Input section						
Max voltage of solar panel	≤150V(V0C); ≤110V(MPPTworking voltage)					
Battery's operating voltage range	9-32V	9-64V	9-32V	9-64V	9-32V	9-64V
Maximum input power	260w(12V) 520W(24V)	130w(12V) 390W(36V) 260W(24V) 520W(48V)	390w(12V) 780W(24V)	260w(12V) 780W(36V) 520W(24V) 1040W(48V)	520w(12V) 1040W(24V)	390W(12V) 1170W(36V) 780W(24V) 1560W(48V)
Output section						
System voltage	12V/24V	12V/24V/36V/48V	12V/24V	12V/24V/36V/48V	12V/24V	12V/24V/36V/48V
Over voltage protection point	16V					
Duration of absorption charging	2hs					
Duration of equalized charging	2hs					
Light control voltage	5V					
MPPT efficiency	99%					
Battery Type						
Battery Type	User default, Sealed, Flooded, GEL, LiFePO4, Li(NiCoMn)O2.					
Absorption charging voltage ※	Maintenance-free lead-acid battery :14.6V, GEL:No;Lead-acid Flooded battery: 14.8V					
Equalized charging voltage ※	Maintenance-free lead-acid battery :14.4V,GEL:14.2V ;Lead-acid Flooded battery: 14.6V					

Float charging voltage ※	Maintenance-free lead-acid battery, GEL, lead-acid Flooded battery :13.8V		
LVR ※	Maintenance-free lead-acid battery, GEL, lead-acid Flooded battery :12.6V		
LVD ※	Maintenance-free lead-acid battery, GEL, lead-acid Flooded battery :10.8V		
Temperature compensation coefficient	-4mV/°C/2V(25°C)		
LiFePO4	Constant voltage charging point :14.4V; low-voltage protection point:11V ; Low-voltage recovery point 12V		
Ternary lithium battery	Constant voltage charging point :12.6V; low-voltage protection point:10V ; Low-voltage recovery point 11.2V		
Other			
Working temperature range	-15°C ~ +50°C		
Humidity	≤90%, No condensation		
Protection class	IP30		
Grounded type	positive grounded		
Dimension(mm)	165x137x73	185x152.5x78	205x167.5x83
Hole size for installation(mm)	143x80	163x90	183x105
Terminal wiring	10mm ² /7AWG	16mm ² /5AWG	
Net weight	716g	1000g	1264g
Optional communication function	Remote control communication, RS232/RS485, RJ45port		
※ Above the parameters are in 12V system at 25°C, twice in 24V system. triple in 36V system, fourfold in 48V system.			

Any changes without prior notice!

Charging mode:

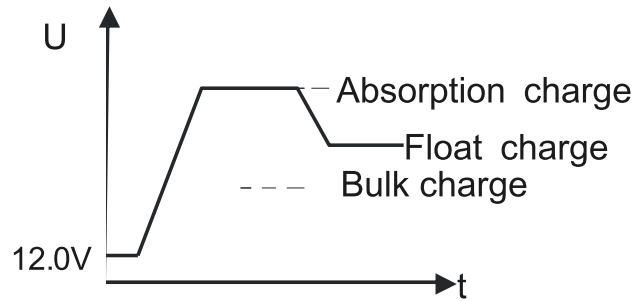

01



02

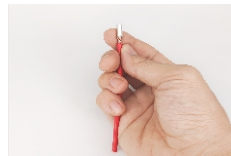

03



04



05



06